



GREENLUX®

BOSTON



BOSTON

- POULIČNÍ SVÍTIDLO LED SMD
- tělo svítidla: hliník
- vhodné na nasvětlení venkovních prostor
- kompenzovaný jalový výkon (PF>0,9)
- vestavné napájení LED CCD

- technologie LED SMD 3030 EPISTAR
- možnost doobjednání montážního ramene (GXSL020)
- životnost 50 000 hodin (podle směrnice ErP)
- pětiletá záruka na celé svítidlo



GXSL020



BOSTON

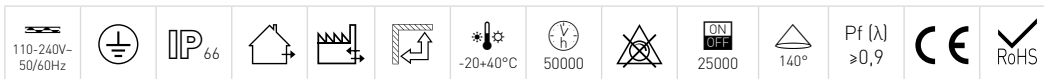

NEUTRAL WHITE

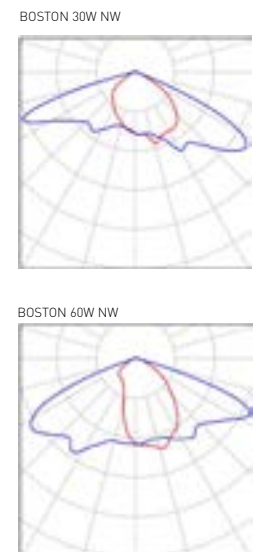
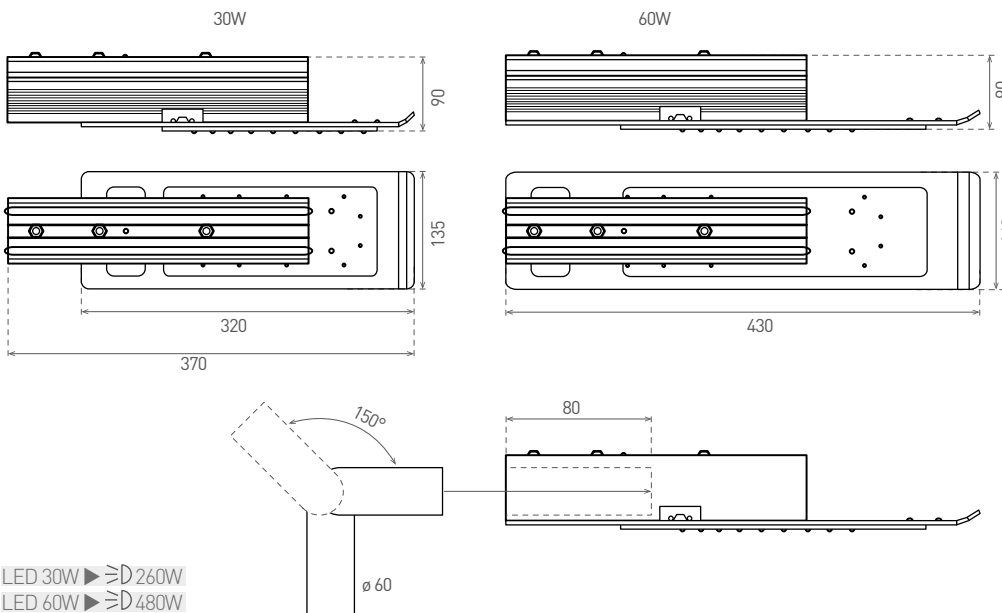

							T_c CCT	R_a CRI			DKC
BOSTON 30W NW	GXSL001	8592660116952	30	3500	36	neutrální bílá/840	4000K	≥80	1,4	1-4	4 266 Kč
BOSTON 60W NW	GXSL002	8592660116969	60	6500	54	neutrální bílá/840	4000K	≥80	1,7	1-4	5 872 Kč
											DKC
BOSTON adapter ø60mm	GXSL020	8592660117461									1 405 Kč